

IncuSafe

Multigas Incubators

50 L



MCO-50M-PE



Personal-size compact Multigas Incubator

Patient-specific, compact design, triple stackable **IncuSafe** Multigas Incubator with variable CO₂ and O₂ control to simulate *in vivo* conditions. During cell culturing, the inCu-saFe germicidal interior and SafeCell UV lamp work continuously to prevent contamination.

Reproduction of *in vivo* conditions

With a unique, solid-state zirconia sensor for precise oxygen control (1-18%; 22-80%), the MCO-50M Multigas Incubator is able to reproduce low oxygen concentrations found in many tissues and organs.

Time-Saving Decontamination

The high-speed decontamination system uses vaporised hydrogen peroxide and UV light. It cleans the chamber of the incubator safely in less than three hours, achieving a minimal 6 log reduction of major contaminants.

Precise Control & Intelligent Monitoring

An OLED alphanumeric keypad allows convenient but secure user control. It can display internal conditions, such as CO₂ level and temperature. Transfer of data is easy via a USB port.

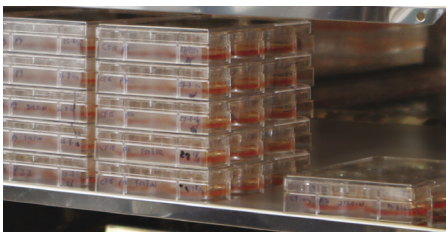

Sensitive Cell Culturing

Culturing cells at physiological oxygen levels allows them to grow faster and live longer, and reduces the frequency of mutations.



Individual Cell Culturing

Compact and stackable these incubators are ideal for individual cell cultures from patient samples or small scale research projects.



Easy to Use

Adjustable audible and visual alarms are standard, along with integrated system diagnostics and predictive performance supervision. The password-protected control panel provides security and minimizes risk of accidental changes in setpoint.

IncuSafe Multigas Incubators

Zirconia O₂ Sensor

The incubator's unique, solid-state, Zirconia O₂ sensor delivers precise control of physiological oxygen levels to simulate *in vivo* conditions.



Dual IR CO₂ Sensor

The incubator's DUAL IR sensor and P.I.D. control enables ultra-fast CO₂ recovery without overshoot, even following multiple door-openings.

Active Background Decontamination

The exclusive inCu-saFe copper-enriched stainless steel alloy interior offers the germicidal properties of copper and the durability of stainless steel. The optional, isolated, SafeCell UV lamp decontaminates circulating air and water in the humidifying pan, without harming cultured cells.

Condensation Management

The 'dew stick' – controlled by Peltier technology – condenses water on its surface, which then drips into the humidifying pan, preventing unwanted condensation in the chamber and possible contamination.

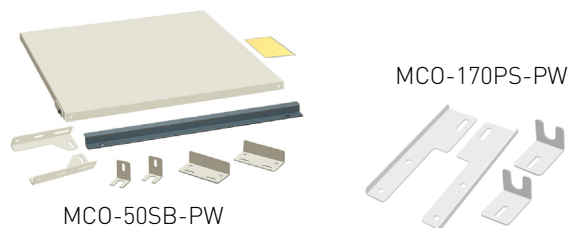
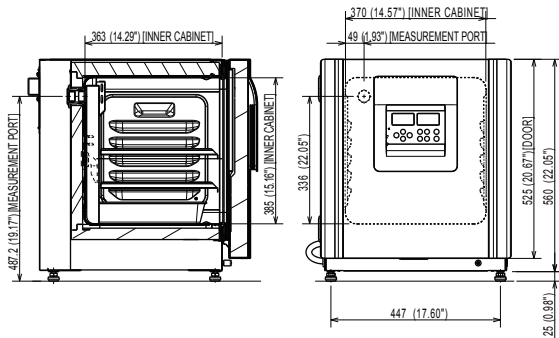

EEA, Switzerland and Turkey only



For medical use

The MCO-50M-PE is certified as a Class IIa Medical Device (93/42/EEC and 2007/47/EC). Applicable countries: Austria, Belgium, Cyprus, Denmark, Finland, France, Germany, Ireland, Italy, Liechtenstein, Luxembourg, Malta, the Netherlands, Spain, Switzerland and the United Kingdom only



For laboratory use

Applicable countries: EEA countries, Switzerland and Turkey

Model Number		MCO-50M-PE
External Dimensions (W x D x H) ¹⁾	mm	480 x 550 x 585
Internal Dimensions (W x D x H)	mm	370 x 363 x 385
Volume	liters	50
Net Weight	kg	46
Performance		
Temperature Control Range & Fluctuation	°C	AT +5 - +50, ±0.1
Temperature Uniformity ²⁾	°C	±0.25
CO ₂ Control Range & Fluctuation ³⁾	%	0 - 20, ±0.15
O ₂ control range & Fluctuation ⁴⁾	%	1 - 18 and 22 - 80, ±0.2
Humidity Level & Fluctuation	%RH	95, ±5
Control		
Temperature Sensor		Thermistor
CO ₂ Sensor		Dual IR
O ₂ Sensor		Stabilized Zirconia Sensor
Display		Digital (White graphic OLED) readable to 0.1 increments
Construction		
Exterior Material		Painted Steel
Interior Material		Stainless Steel Copper-Enriched Alloy
Insulation Material		Styrene AcryloNitrile copolymer
Heating Method		Direct Heat & Air Jacket System
Outer Door	qty	1
Outer Door Lock		N/A
Field Reversible Door		Included
Inner Door	qty	1
Shelves	qty	2 x Stainless Steel Copper-enriched Alloy
Shelf Dimensions (W x D x H)	mm	353 x 308 x 12
Max. Load per Shelf	kg	7
Max. Shelf Capacity	qty	6
Access Port	qty	1
Access Port Position		Rear upper left
Access Port Diameter	∅ mm	30
Alarms		(R = Remote Alarm, V = Visual Alarm, B = Buzzer Alarm)
Power Failure		R
Out of Temperature Setting		V-B-R
High Temperature		V-B-R
Out of CO ₂ Setting		V-B-R
Out of O ₂ setting		V-B-R
Door open		V-B
Electrical and Noise Level		
Power Supply	V	220-240
Frequency	Hz	50
Noise Level ⁵⁾	dB	29
Options		
SafeCell UV [®] System		MCO-170UVS-PE
H ₂ O ₂ Decontamination Board		MCO-50HB-PW
Electric door lock with password		MCO-170EL-PW
H ₂ O ₂ Vapor Generator		MCO-50HP-PW
H ₂ O ₂ Reagent, pack of 6 bottles		MCO-5H202-PE
CO ₂ Gas Pressure Regulator		MCO-010R-PW
N ₂ Gas Pressure Regulator		MCO-010R-PW
Automatic CO ₂ Cylinder Changeover System		MCO-5GC-PW
InCu-saFe [®] Shelf		MCO-50ST-PW
Double stacking bracket		MCO-170PS-PW
Stacking plate		MCO-50SB-PW
Roller Base		MCO-50RB-PW

Appearance and specifications are subject to change without notice.

¹⁾ Exterior dimensions of main cabinet only, excluding handle and other external projections

²⁾³⁾⁴⁾ Ambient temperature 25°C, setting 37°C, CO₂ 5%, O₂ 5%, no load

⁵⁾ Nominal value

* MCO-50M-PE requires MCO-50HB-PE, MCO-170EL-PW, MCO-50HP-PW and SafeCell UV option for H₂O₂ decontamination



WolfLabs

Pricing on any accessories shown can be found by keying the part number into the search box on our website.

The specifications listed in this brochure are subject to change by the manufacturer and therefore cannot be guaranteed to be correct. If there are aspects of the specification that must be guaranteed, please provide these to our sales team so that details can be confirmed.

www.wolflabs.co.uk

Tel : 01759 301142

Fax : 01759 301143

sales@wolflabs.co.uk

Please contact us if this literature doesn't answer all your questions.